

Part Number	PT-0816B3MP
Effective Focal Length	8.0mm
Mount	M12x0.5
Sensor Format	1/2.5"
Aperture	1.6
Field Of View (Horiz)	43.2 Deg
Minimum Object Distance	0.2m
Net Weight	8g
Chief Ray Angle	< 11 Deg
Distortion	-4.0%

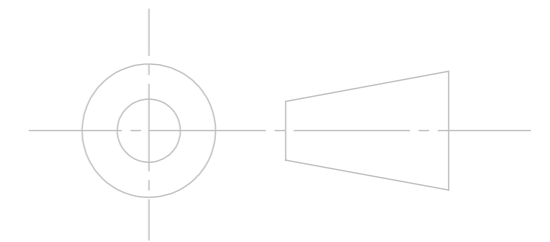
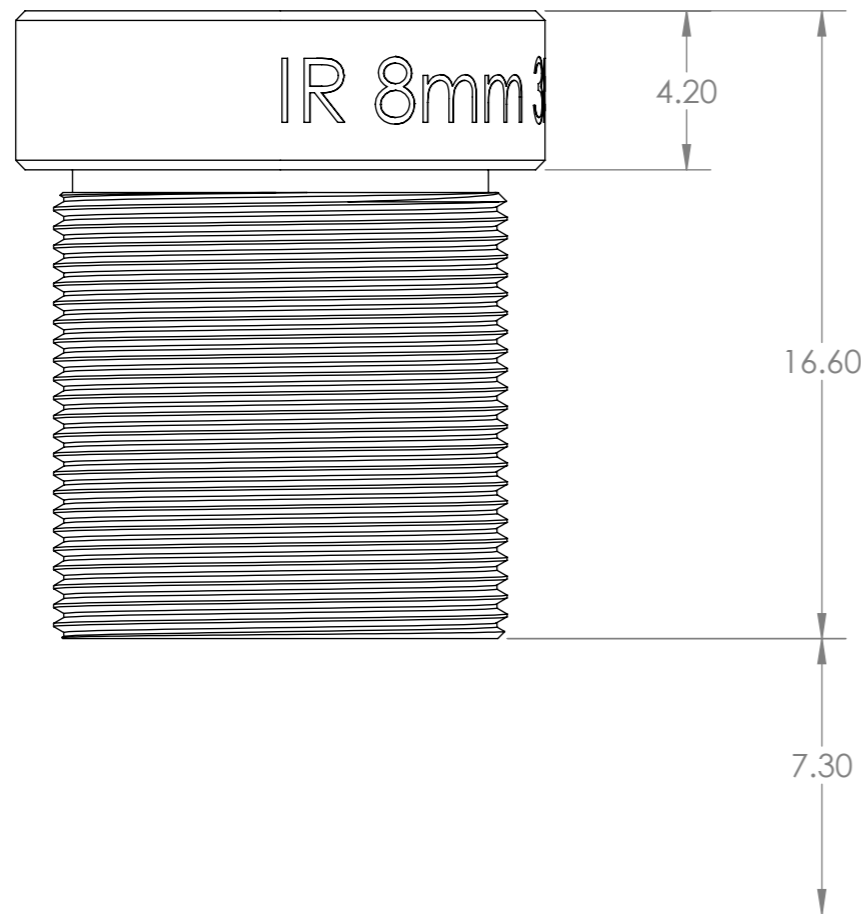

UNLESS OTHERWISE SPECIFIED: DIMENSIONS ARE IN MILLIMETERS SURFACE FINISH: TOLERANCES: LINEAR: ANGULAR:			DO NOT SCALE DRAWING		DEBUR AND BREAK SHARP EDGES			
DRAWN: THARAKA G			SIGNATURE:		DATE:		REVISION: 1.00	
CHK'D:			SIGNATURE:		DATE:		FINISH: Black Anodized	
APPV'D:			SIGNATURE:		DATE:		MATERIAL: Aluminum/Glass	
MFG:			SIGNATURE:		DATE:		PART NO.: PT-0816B3MP	
Q.A:			SIGNATURE:		DATE:		WEIGHT:	
							TITLE: 8mm, F1.8 CCTV LENS	
							SCALE: 2:1	
							SHEET 1 OF 1	
							A3	